

### GATHER FLIP TABLE



#### Description

##### Gather - Table - Crescent Curve - Flip Legs in Fusion Maple

Our Flip Top Gather Tables bring together function and versatility, ideal for creating flexible learning spaces. The fixed height legs contain a simple to use, durable, pull latch mechanism that allows users to quickly flip the table top from a horizontal writing surface to a vertical presentation board. When the tables are not needed they can quickly be wheeled away and nested together for storage.

Suitable for all learning environments including K-12, higher education and common spaces.

#### Product features

- Edges all smoothed and finished
- Nests together for storage
- Can be tilted for mobile display
- Lockable casters

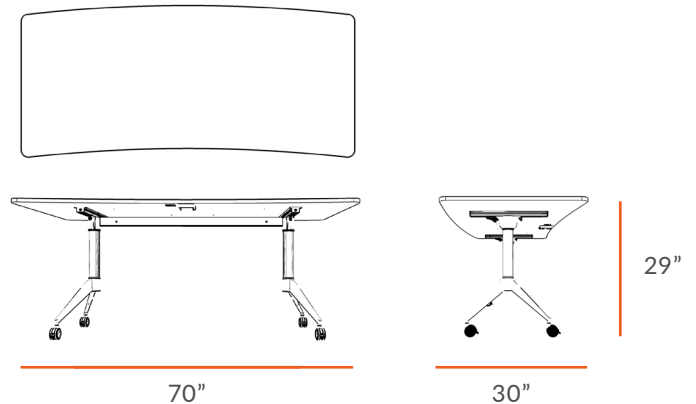

#### Materials

- Europly FSC certified hardwood plywood (FSC R 012337)

# natural pod™

## TECHNICAL DRAWING

### GATHER FLIP TABLE

LENGTH 70"

DEPTH 30"

HEIGHT 29"

Dimensions indicated are approximate. Please contact us if you require clarification.

